



# Telescopic Windmill Installation Manual



[www.outdoorwatersolutions.com](http://www.outdoorwatersolutions.com)

181 Industrial Circle E. Springdale, AR 72762

Toll Free (866) 471-1614

## TABLE OF CONTENTS

OWS Accessories	3
3-5 Year Limited Warranty	4
Contents	5
Telescopic Tower Assembly Steps 1-5	6-7
Head & Tail Assembly Steps 9-12	8-12

## **Outdoor Water Solutions Accessories**

### **Outdoor Water Solutions Weighted Air Line**

Weighted Air Line can be used in the pond to keep your air line on the bottom. This allows for easier fishing, boating, swimming, etc. and also keeps your air line from freezing on the surface in climates where ice is a possibility. Available in 50' and 100' lengths.



### **Freeze Control System**

An Outdoor Water Solutions Freeze Control System keeps your air line from freezing in the winter due to excess condensation in the line. A Freeze Control System is HIGHLY RECOMMENDED and will keep your warranty intact if freezing temperatures are common in the winter months.

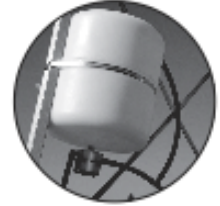

### **2-Way & 3-Way Selector Valves**

These high quality valves allow you to adjust airflow between multiple airstones or between airstones and water pumps if you are running both with one windmill.



### **Airstone Housing Bucket**

These high quality buckets are ideal for protecting the airstone from the mud and debris common in most ponds and lakes.



### **Airstone Marker – Duck Decoy**

The use of a duck decoy allows you to mark the airstone and can also serve as a way to lift your Airstone Housing Bucket if needed to move or service.



## **The Outdoor Water Solutions 3/5 Year Limited Warranty**

This warranty covers all Outdoor Water Solutions, Inc. Windmill products for 3 years from purchase date against defects in workmanship and five years from purchase date against defects in the compressor.

1. Outdoor Water Solutions, Inc. (OWS) will replace or repair any part deemed to be defective by Outdoor Water Solutions, Inc., due to defects in quality and/or workmanship within a 3 year period from the initial date of purchase. Functional windmill compressors are covered for 5 years from date of purchase against major defects. Note: Diaphragm and check valve replacement are considered routine maintenance if needed.
2. Warranty does not apply to OWS products which were installed incorrectly, subject to an accident, neglect or damage due to excess winds.
3. This warranty does not apply to damage caused by severe weather. Private insurance coverage is recommended.
4. When an OWS Freeze Control System has not been used, warranty coverage may not apply to damages incurred to an Outdoor Water Solutions Aeration System as a result of a blocked line. The use of an Outdoor Water Solutions Freeze Control System is **HIGHLY RECOMMENDED** in geographical areas where freeze may be a concern.
5. Product returned for warranty repair must be returned to the address specified by the manufacturer and any warranty product sent to the customer will be sent freight prepaid.
6. Warranty coverage may be void if parts other than genuine Outdoor Water Solutions parts are utilized for repair or attached to an Outdoor Water Solutions Aeration System.
7. Proof of purchase date is required for warranty repairs.
8. If you have any warranty concerns, please contact Outdoor Water Solutions, Inc. at 1-866-471-1614 in Canada or USA. International customers can call 1-866-471-1614 or 1-479-756-1614 with any warranty concerns.

### **Safety Precautions**

1. Please do not attempt any service or repairs to the windmill in a high wind situation.
2. Make sure the blades are secured when service or repair is necessary for compressor. We recommend laying the windmill down when working on it vs. trying to do repairs while it is standing. A sudden gust of wind can physically turn the rotor head causing possible injury.
3. **DO NOT** get near the windmill in high wind situations or in a thunderstorm.
4. **DO NOT** allow children to play on or near the windmill.

### **Return Materials Authorization**

A return materials authorization (RMA) number must be obtained prior to returning any product for warranty work.

You can call the Outdoor Water Solutions warranty department at the following numbers:

Canada and USA 1-866-471-1614

International (outside Canada and USA) 1-866-471-1614 or 1-479-756-1614

**NOTE:** Serial numbers are located inside the compressor

**Outdoor Water Solutions, Inc.** recommends that, for future reference, you keep this Installation Manual in a convenient location.

Serial number: \_\_\_\_\_ Date of purchase: \_\_\_\_\_

**NOTE: Make sure all components and accessories are accounted for before beginning assembly.**

### ***Compressor Box***

#### ***Single Diaphragm***

1pc - Free-Air Compressor  
1pc – Foot Valve  
1pc – Pivot Tube Washer  
1pc –Airstone

### ***Blade and Tail Box***

#### ***Single Diaphragm***

1pc - Dome  
12pcs - Blades  
12pcs - Blade Braces  
1pcs - Wheel Hub  
2pcs - Tail Fins  
1pc - Pivot Tube  
2pcs - OWS Decals  
1pc – Blade and Tail Bolt Package

### ***Telescopic Tower Box***

1pc – Telescopic Pole Hardware Package  
1pc – 7” dia. x 10’ long pole section  
1pc – 4” dia. x 10’ long pole section  
1pc – 2” dia. x 5’ long pole section

### ***Tail Arm Box***

2pc – Tail Arms

### ***Accessory Box***

100’ – Poly Tubing

## **STEP 1:**

**NOTE:** A CONCRETE PAD MUST BE POURED TO ENSURE PROPER ANCHORING OF THE TELESCOPIC POLE TOWER.

1. 10 FEET WIDE BY 10 FEET LONG BY 6 INCHES THICK. TYPE "25 MPA" CONCRETE. THIS WILL PROVIDE A BASE WEIGHT OF APPROXIMATELY 5000 POUNDS AND WILL COUNTER BALANCE THE TELESCOPIC POLE AND HEAD ASSEMBLY.

2. REINFORCE THE CONCRETE PAD WITH ONE (1) ROW OF 5/8" REBAR OFF CENTER IN EACH DIRECTION. THE ANCHOR BOLTS SHOULD BE CONNECTED TO THE REBAR BY EITHER WELD OR TIE WIRE FOR ADDITIONAL SUPPORT.

**NOTE: DUE TO THE VARIED NATURE OF ANCHORING SYSTEMS AVAILABLE, OWS DOES NOT PROVIDE ANCHORING HARDWARE (NUTS, BOLTS AND WASHERS). OWS RECOMMENDS TO USE GRADE 8 ONE (1) INCH DIAMETER BOLTS, NUTS AND WASHERS. THE LENGTH WILL DEPEND ON THE THICKNESS OF THE CONCRETE PAD.**

3. THE ANCHOR BOLTS MUST BE POSITIONED AND SPACED CORRECTLY TO ENSURE A CORRECT FIT WITH THE TELESCOPIC POLE BASE PLATE. PLEASE SEE DRAWING BELOW FOR THE PROPER SPACING OF THE ANCHOR BOLTS.

4. IF THE PAD IS TO BE BURIED UNDER THE GROUND IT IS BEST TO INCORPORATE A 16 INCH DIAMETER SECTION OF SAUNA TUBE INTO THE TOP CENTRE OF THE CONCRETE BASE. THIS WILL RAISE THE ANCHOR BOLTS AND CONCRETE BASE OUT OF THE GROUND ALLOWING THE TELESCOPIC POLE TO BE ANCHORED ABOVE GROUND LEVEL. THIS IS IMPORTANT AS IT WILL ALLOW THE BOLTS AND HINGE TO OPERATE CORRECTLY AND ALSO PREVENT RUSTING.

5. ALL ANCHOR BOLTS SHOULD HAVE A 90 DEGREE BEND WITH A MINIMUM OF THREE (3) INCHES TURNED HORIZONTAL IN THE CONCRETE BASE. THE VERTICAL LENGTH OF THE ANCHOR BOLTS IS DEPENDENT ON THE THICKNESS OF THE CONCRETE BASE AND THE HEIGHT OF THE RAISED CENTER AREA ON TOP OF THE CONCRETE BASE. ENSURE THE ANCHOR BOLTS ARE POSITIONED REBAR IN THE CONCRETE BASE. ALSO ENSURE THE ANCHOR BOLTS ARE ATTACHED OR TIED TO THE REBAR BY WELD OR TIE WIRE.

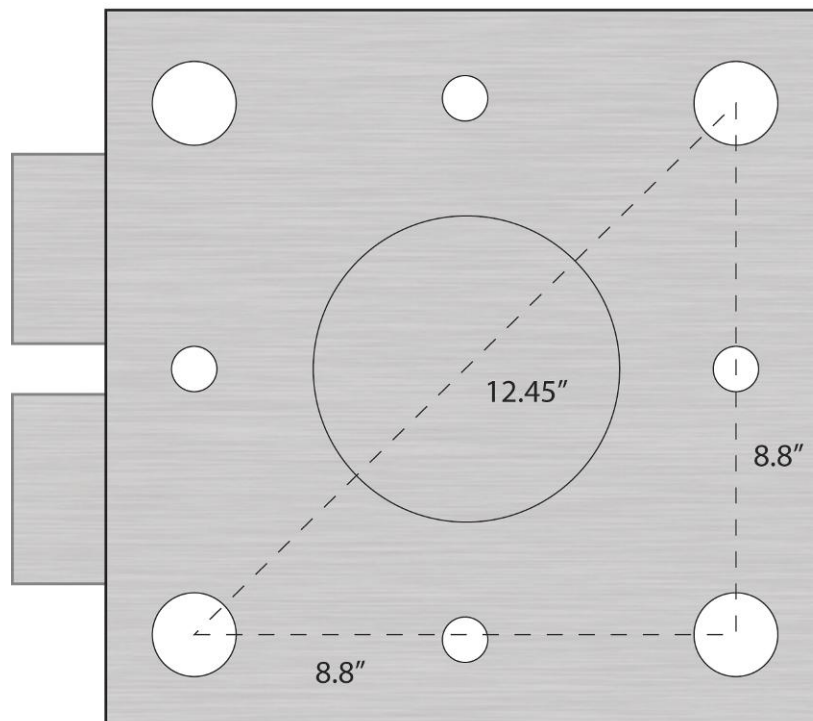

## **STEP 2:**

YOU ARE NOW READY TO BEGIN THE ASSEMBLY OF THE TELESCOPIC POLE TOWER.

1. THE BASE PLATE MUST BE ATTACHED AND LEVELED TO THE ANCHOR BOLTS, WHICH WERE INSTALLED IN STEP 1.
2. THREAD ONE (1) NUT AND ONE (1) WASHER (NOT PROVIDED) TO THE BOTTOM OF EACH ANCHOR BOLT. THESE NUTS WILL ALLOW FOR LEVELING OF THE BASE PLATE.

**NOTE:** LAY THE TELESCOPIC POLE ON A SAW HORSE OR SIMILAR WHILE ATTACHING THE BASE PLATE TO THE CONCRETE PAD AND ASSEMBLING THE TELESCOPIC POLE.

3. SLIDE THE BASE PLATE OVER THE ANCHOR BOLTS AS SHOWN BELOW.
4. PLACE ONE (1) WASHER AND THREAD ONE (1) NUT ON EACH ANCHOR BOLT, OVER THE BASE PLATE.
5. TIGHTEN THE NUTS BELOW THE BASE PLATE AND THEN TIGHTEN THE NUTS ON TOP OF THE BASE PLATE. USE A STANDARD LEVEL TO ENSURE THE BASE PLATE IS LEVEL IN ALL DIRECTIONS.  
**NOTE:** IF THE BASE PLATE IS NOT LEVELED CORRECTLY THE WINDMILL WILL TILT WHEN IT IS ERECTED. IT IS VERY IMPORTANT TO ENSURE PROPER LEVELING AT THIS POINT IN THE INSTALLATION.
6. ONCE THE BASE PLATE IS LEVELED YOU ARE READY FOR STEP 3 OF THE ASSEMBLY PROCESS.

## **STEP 3:**

1. BOLT THE FOUR (4) INCH WIDE BY TEN (10) FOOT LONG SECTION TO THE SEVEN (7) INCH WIDE BY TEN (10) FOOT LONG SECTION USING THE SIX (6) 3/8" BOLTS AND SIX (6) 3/8" WASHERS (GRADE 8) PROVIDED.

## **STEP 4:**

1. BOLT THE TWO (2) INCH WIDE BY FIVE (5) FOOT LONG SECTION TO THE FOUR (4) INCH WIDE BY TEN (10) FOOT LONG SECTION USING THE FOUR (4) 3/8" BOLTS AND FOUR (4) 3/8" WASHERS (GRADE 8) PROVIDED.

## **STEP 5:**

1. INSERT THE PLASTIC TOWER TUBE INTO THE TOP OF THE TWO (2) INCH WIDE TELESCOPIC POLE SECTION.

**NOTE:** THE SLIT IN THE PLASTIC TOWER TUBE MUST LINE UP WITH THE 1/4" HOLE IN THE TOP SECTION.

2. THREAD THE SUPPLIED 1/4" GREASE ZERK IN THE 1/4" HOLE IN THE TELESCOPIC POLE AND THROUGH THE SLIT IN THE PLASTIC TOWER TUBE.

**NOTE:** THIS GREASE ZERK HOLDS THE PLASTIC TOWER TUBE IN PLACE AND PROVIDES LUBRICATION FOR THE WINDMILL HEAD TO SPIN FREELY.

## **STEP 7:**

Note: Do Not tighten any of the blades on the hub until the blade braces have been installed.

Note: Hub must face down when installing blades and blade braces (face down means the smaller bolt hole in the front must be facing down. The exposed 1" hole for the shaft should face up). This allows for the proper blade pitch, slightly forward, when complete.

1. Install all twelve blades (BLA) as shown in Illustration 3. Make sure that the bolts and washers go through the blade with the nuts attached on the inside of the hub.

### **ILLUSTRATION 3**

1/4" x 3/4" BOLTS & NUTS  
(PACKAGE C)

1/4" Nuts - On inside of Hub

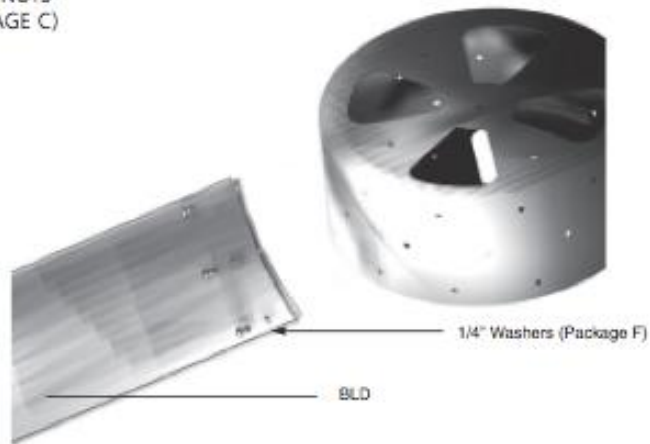

## STEP 8:

### Blade Installation:

Illustration 4

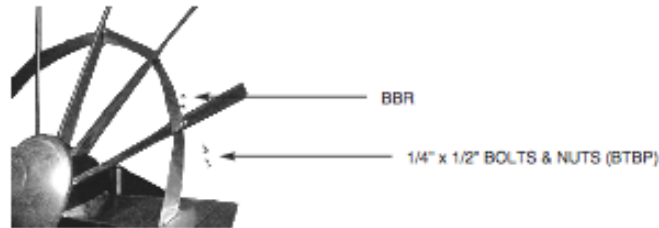

1. Install all twelve blade braces (BBR) as shown in Illustration 4 above.

2. Completely tighten all bolts on both the blades and blade braces (but only after all have been assembled). This allows everything to stretch as needed so you can put everything together.

Note: Hub must face down when installing blades and blade braces (face down means the smaller bolt hole in the front must be facing down. The exposed 1" hole for the shaft should face up). This allows for the proper blade pitch, slightly forward, when complete.

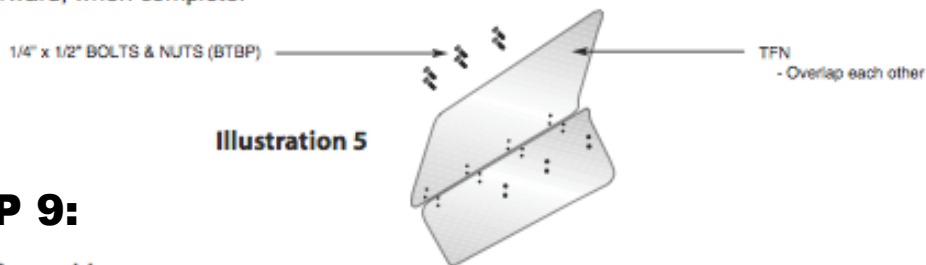

Illustration 5

## STEP 9:

### Tail Pre-Assembly:

1. Pre-assemble tail fins (TFN) for step #10. Overlap each tailfin by lining up the bolt holes in the channel of both. Insert 1/4" x 1/2" bolts & nuts (btbp) in the back six bolt holes and tighten. See Illustration 5.

2. Attach tail arms to tail fin in the front two bolt holes using 1/4" x 3/4" bolts and 1/4" nuts as shown in Illustration 6. Tighten when tail arm and tail fin are straight.

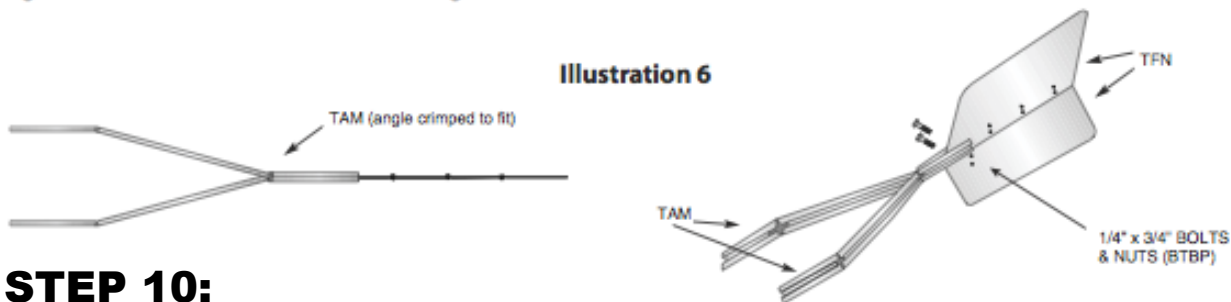

Illustration 6

## STEP 10:

### Pivot Tube and Tail Installation:

1. Insert "U" bolt (package G) through the two holes in the back of the compressor and secure with 5/16" flange nuts (package B). Do not tighten tight – leave loose until pivot tube has been installed.

2. Slip the pivot tube (PVT) (hole at the top of the tube) through compressor bottom, through 'u' bolt clamp and through the compressor top plate. Align the hole in the pivot tube to the compressor air line hose. Tighten the 'u' bolt clamp with 5/16" nuts from inside the compressor until pivot tube is held securely in place. See Illustration 7.

3. Install your preassembled tail arms and tail fins onto the compressor. The tail arms and tail fins are attached to the compressor body using 5/16"x 1/2" bolts (package A) and 5/16" flange nuts (package B). Note: Insert bolts from the outside and use nuts on the inside of the compressor housing. Tightening of these nuts is done from the inside of the compressor, through the side opening. See Illustration 7. After these are tightened, replace side cover plate.

Note: Cover plate will be very snug when sliding behind the tail arms. If too tight, slightly loosen the two bolts, insert

side cover plate, then re-tighten the bolts.

### ILLUSTRATION 6

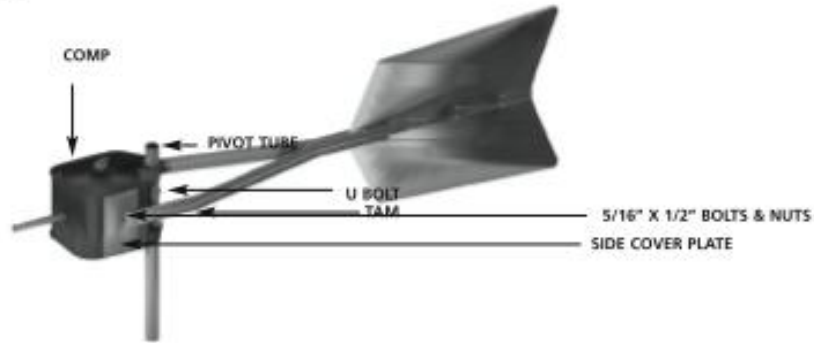

### STEP 13 - Setup Windmill Components:

Setup of windmill components:

1. Install the blade assembly onto the compressor crankshaft and tighten the allen screws in locking collar with supplied 5/32" allen wrench (package A) on the flat sections of the crankshaft photo 1). Note: A little lubricant on the crankshaft can help make this step easier. If needed, place the blade assembly on the ground and gently push down on the compressor to secure it into the 2 locking collars. Attach blade hub assembly (HUB) to crankshaft using 5/16" x 1/2" bolt (package A) into the end of the shaft (photo 2). **Make sure all allen screws and the front mounting bolt are tight.**

2. Install the dome (DOM) on the outside of the blade hub assembly (HUB). Secure with the four 10 x 1/2" sheet metal screws (package G) to blade hub assembly (HUB).



3. Install the completed rotor head unit onto the tower. With tower being supported by a Saw horse or some type of stand, slide pivot tube washer (PW) over pivot tube. Then insert pivot Tube into the plastic tower tube inside 2" telescopic pole.

4. After the completed rotor head unit has been mounted at the top of the tower, insert the air line up through the tower (starting at the bottom and go out the top of the pivot tube). Put a small amount of grease onto each end of the 1/2" x 1/2" ninety degree hose barb. Connect one end of the ninety degree hose barb to the line running down the tower and to the pond. Push the air line back down and insert the 90 degree hose barb through the 9/16" hole in the pivot tube and into the 1/2" air line connecting to the compressor. See Illustration 8. A long handled screwdriver or

### ILLUSTRATION 8

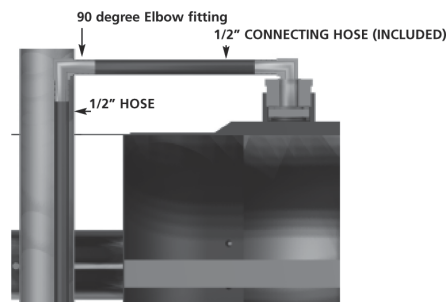

wrench can help leverage the hose barb into the 1/2" connecting hose.

6. After the above procedures, stand up the completed unit on the site. A wrench or similar device is recommended.

**Please note:** Anchoring of Outdoor Water Solutions Windmill Towers. - Outdoor Water Solutions, Inc. will not determine soil and wind conditions for any windmill erection. Therefore, these conditions must be determined by the customer. Anchoring of the windmill tower is very important. It is the customer's responsibility to adequately anchor the tower. Outdoor Water Solutions, Inc. supplies a basic anchoring kit with each unit. However, we strongly recommend the use of concrete pilings, a concrete pad or screw in anchors. High winds or light soil conditions can cause the windmill to fall over, physically damaging the rotor head and other components. The customer is responsible to anchor the windmill adequately or consult the appropriate people to do so.

### **Instructions for Placing Airstone in Pond**

We recommend that you put your airstone into a rubber or plastic bucket to help protect it from the mud and debris common in the bottom of most ponds. A 3-5" layer of small rock, sand or even concrete put into the bottom of the bucket can help weigh the bucket down so it sits on the bottom.

We also suggest installing the airstone into the deep part of the pond to ensure complete circulation of your water. The exception to this would be if you're wanting to keep the water open for watering livestock in the winter, then you can put the stone closer to the shoreline (or move it there in the fall). You can also place the airstone in a shallow area if you are in a northern climate and have trout, walleye, Northern pike or muskie in the pond or lake and want the deep parts of the pond to remain colder in the summer months.

The use of OWS Weighted Air Line will help keep the airline submerged and on the bottom of the pond. In the absence of using weighted air line, tie rebar, bricks, blocks, etc. to the non-weighted air line to help keep it submerged.

If you are attaching multiple airstones or a combination of airstones and a water pump, then using an OWS 2-way or 3-way Selector Valve is needed. These are available in combinations and are made up of high quality brass ball valves that allow you to adjust and regulate the airflow between multiple accessories.

Note: Air will travel to the point of least resistance or to the shallow airstones first. Adjusting the airflow so that it goes to the deeper airstones is usually required.

Note: Backflow valve assembly attaches to the airline and the airstone to keep water from backing up into the airline.

### **CONGRATULATIONS!!!**

We hope your new Outdoor Water Solutions Windmill will give you many years of joy!

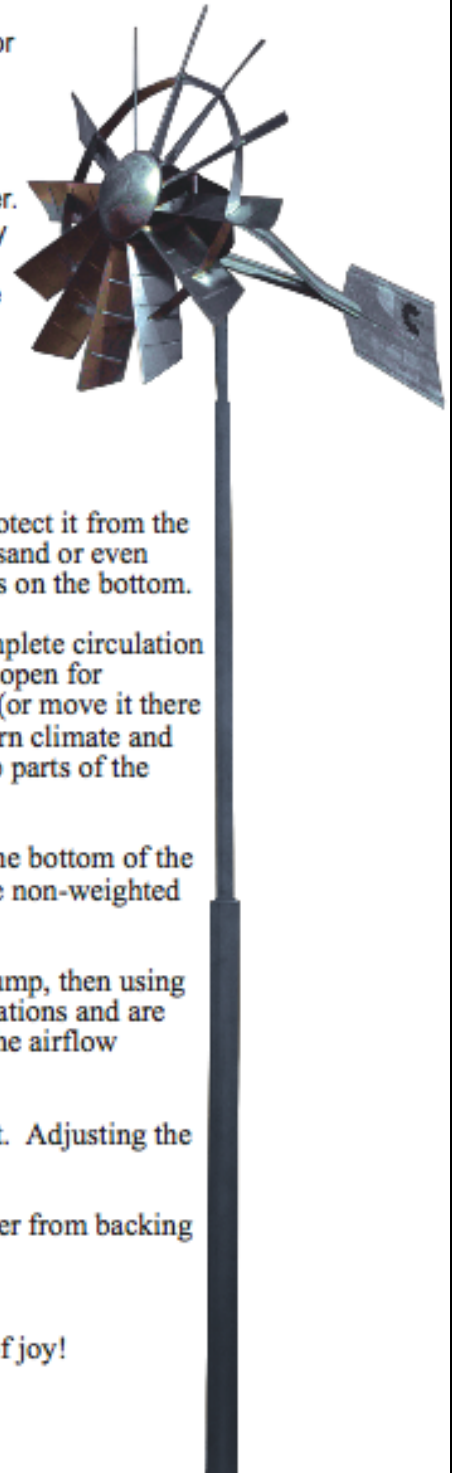

**CONGRATULATIONS!  
YOU HAVE COMPLETED A TELESCOPIC POLE.**

3/4" x 2 1/2" Bolt and Washer

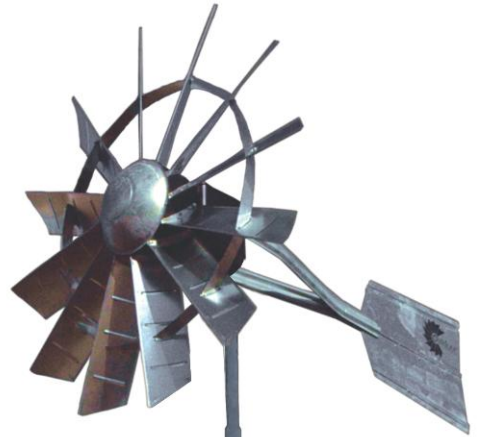

**FIGURE 'A'**

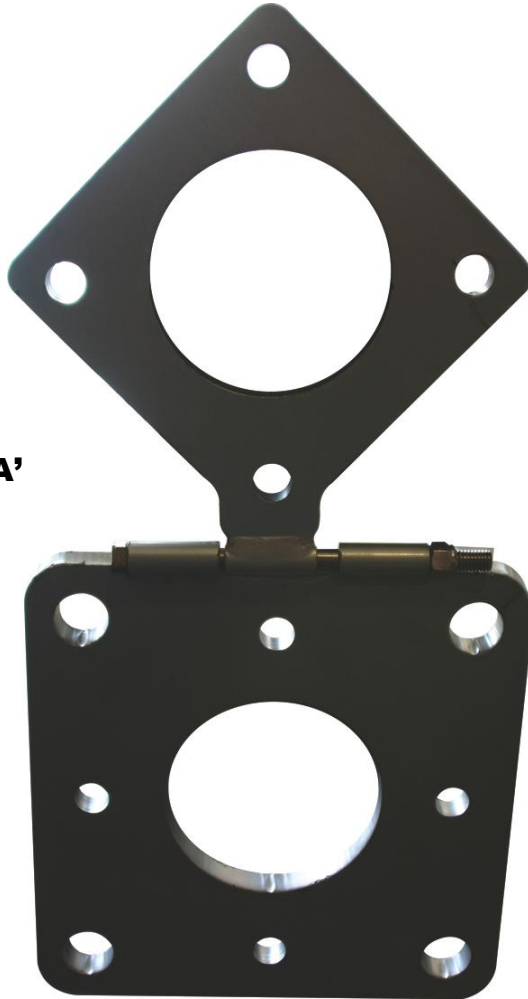

3/4" Nut and Washer